

GET CONNECTED

HUMMEL AG

Cable Glands

Basic Training



General Information about Cable Glands

- Definition
- Application examples

HUMMEL products

- General structure cable glands
- Polyamide cable glands HSK-K
- Nickel plated brass and stainless steel cable glands HSK-M
- EMC cable glands HSK-M-EMC
- Special applications
 - // Hygienic design cable glands
 - // Varia Pro series
 - // Cable glands for Ex applications
- Accessories
- Standards and approvals
- Quality

Conclusion / Summary

- **Definition**
- **Applications examples**



Definition cable gland per EN 62444:

Device, designed to insert a cable, a conduct or an isolated conductor in a casing which delivers tightness and detention. This device can also provide other functions like electrical grounding, isolation, bend protection, strain-relief or a combination of these.

Intention:

They are used for a safe insertion of cable or wire

Targets:

- tightening against dust / water / dirt
- strain-relief and retention force
- twist protection
- further specific characteristics like bend protection, etc

How not to do it!



- industrial application, electrical installations
- housings and control boxes, engines, gears
- mechanical engineering and plant constructions
- transport, vehicle construction, shipbuilding, railway and aviation
- food and beverages industry
- lightning and tunnel constructions
- wastewater treatment and wastewater technology
- chemical industry, gas- and oil industry
- solar applications and photovoltaic
- automation technology

Standard
Cable Glands

Special
Cable Glands



HUMMEL Products

- General structure HSK
- Materials
- Polyamide cable glands
- Nickel plated brass glands / stainless steel cable glands
- EMC cable glands
- Special applications
 - // Hygienic design cable glands
 - // VariaPro series
- Cable glands for Ex applications
- Accessories

HSK-K

HSK-M

headnut



headnut

sealing insert



sealing insert

body



clamping insert

o-ring (optional)



body

o-ring



standard sealing insert

reduced sealing insert

Materials of the HUMMEL cable glands

plastic bodies

Polyamide
PVDF

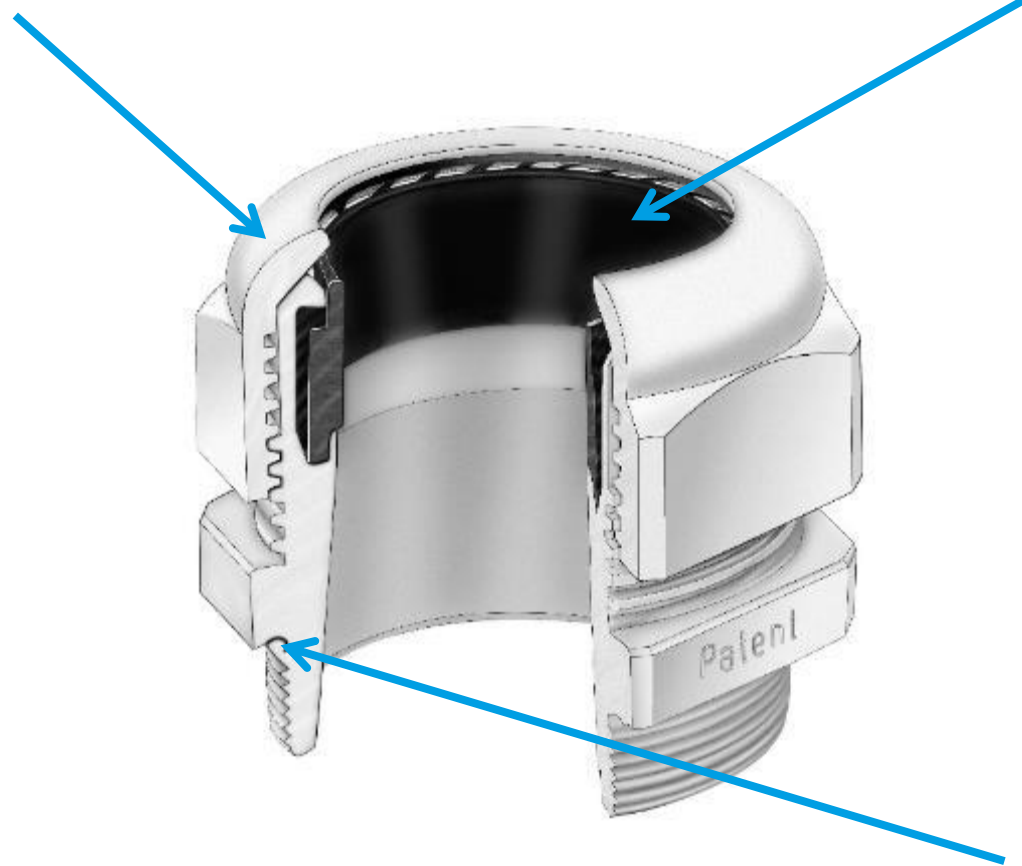

sealing

NBR
FKM
VMQ

o-ring

NBR
FKM
VMQ

metal bodies

Nickel plated brass
Nickel plated brass lead free
INOX 1.4305
INOX 1.4404



clamping insert

Polyamide
PVDF

HSK-K

- Material above market standard: Polyamide V0 according UL94
- Tightness above market standard: IP54, with O-ring IP68 10bar, IP 69K
- Operating temperature: -40°C to +100°C
- Available in grey (RAL7035), black (RAL9005)
- TOPSELLER!



Technical features of the HSK-K

The **untwist protection** avoids dismantling



Flexible overlapping clamping splines prevent the form seal from being pulled out of the fitting



The **form seal** allows an **IP68 10bar** as well as **IP69K**

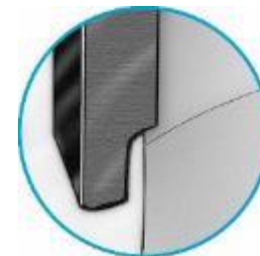

Optional o-ring is chambered and can not be squeezed out. Additional **molded sealing lip** ensure without o-ring at least **IP54**

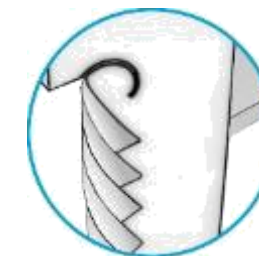

More standard variants

HSK-K-Multi / FLAKA

- For flat cables and multiple cable insertion of cables
- Customized drilling patterns!



HSK-K-PVDF

- Resistant against ozone, UV-radiation, salt water and high temperatures
- Popular in food & beverages industry



More standard variants

HSK-K-Flex

- Bending protection for soft cables



HSK-W

- Deflection of the cable entry into the housing, e.g. in a installation situation with little space.
- USP: You can unfold it!



HSK-W-Flex

- Combination of these two products



Tube part vs. Form seal

- tube part = low price solution
- form seal = premium solution

Advantages:

- + enables a higher IP-Rating
- + no tearing out of sealing insert
- + therefore increased safety for the system

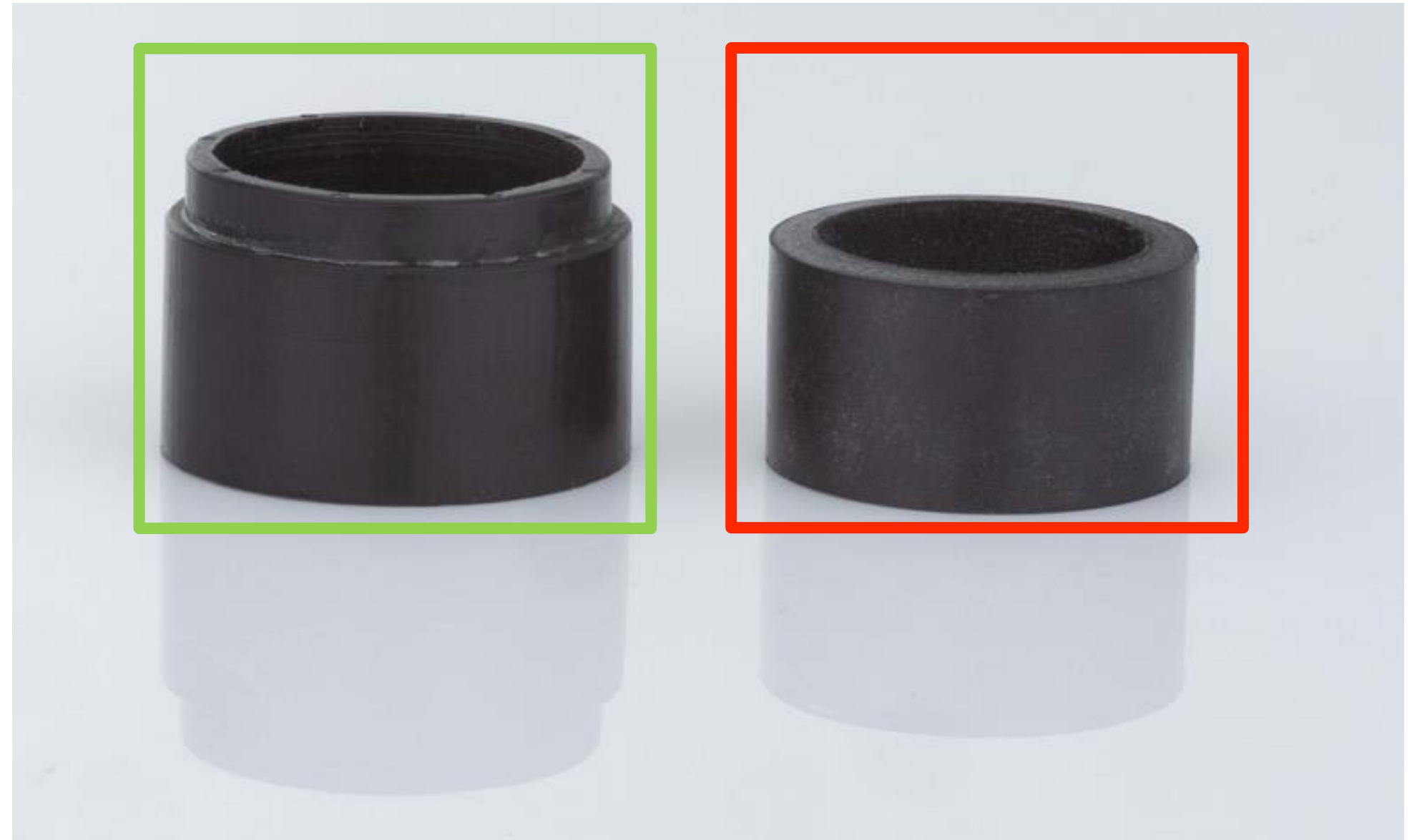

HSK-M

- Material: Nickel plated brass
- Material clamping insert: Polyamid V0 according UL94
- IP protection category above market standard:
IP68 at 10bar, IP 69K
- Operating temperature -40°C to 100°C
- TOPSELLER!



Technical features of the HSK-M

Flexible overlapping clamping splines prevent the form from being pulled out of the gland

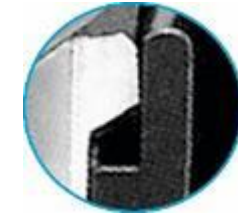

The **internal sealing lip** provides **optimum tightness** between the clamping insert and the body

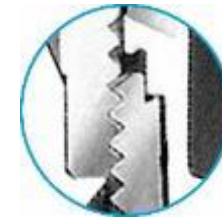

The **form seal** allows **IP68** at **10bar** as well as **IP69K**

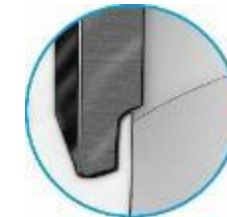

The **anti-rotation protection** prevents the twisting of the Clamping insert and the cable during assembly

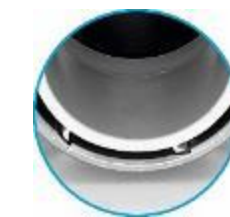

More nickel plated brass glands

HSK-M-Flex

- Bending protection for soft cables / wires



HSK-M-Multi / FLAKA

- For flat cables and multiple cable insertion of cables.
- Customized drilling patterns!



HSK-M-W

- Redirection of the cable entry into the housing



HSK-K-PVDF

- Resistant against ozone, UV-radiation, salt water and high temperatures



More nickel plated brass glands

HSK-MZ

- For a higher strain relief → cable can not be pulled out



HSK-Mini / HSK-XL

- Mini: cables from 2mm
- XL: cables up to 90mm



HSK-INOX

- Cable gland made out of stainless steel
- Suitable for applications with high requirements, e.g. saltwater or acid



EMC Basics

EMC = Electromagnetic Compatibility

Refers to the ability of a technical device. Not to interfere with other devices due to unwanted electrical or electromagnetic effects or to be interfered with by other devices.

Electromagnetic compatibility means the absence of effects on other devices and equipment that lead to unintentional or intentional malfunctions of electrical or electronic equipment caused, for example, by electric, magnetic or electromagnetic fields and processes.

The proper construction and design of electrical equipment is essential to ensure that it functions in an electromagnetically compatible manner. Proof and confirmation of sufficiently low interference sensitivity and interference emission are regulated by EMC directives and EMC standards.

EMC – cable glands

HSK-M-EMC

- EMC connection by putting the cable shielding over the o-ring
- Complex mounting

HSK-M-EMC-D

- EMC connection by a metallized polyamide clamping insert
- Durable connection and easy mounting

Metrica-M-EMC-E

- Low cost version of the EMC-D
- Very thin material for EMC connection, fast material fatigue



Hygienic design

Mars recalls chocolate bars in 55 countries after plastic found in product

Britain, France, the Netherlands and Germany are affected by recall after customer finds piece of red plastic in Snickers bar



Hygienic design

HSK-INOX-HD

- Good for food & beverages industry



ideal for
foam-cleaning

HSK-INOX-HD-Pro

- Perfect for food & beverages industry



ideal for high-
pressure cleaning

Why blue?



Very few **blue** foods!



Varia Pro series

VariaPro Rail

- Developed especially for railway applications
- Certified according to EN 45545-2/3



VariaPro Temp

- Cable gland for extreme temperatures: -60C° to $+200\text{C}^{\circ}$



Ex-cable glands

 BP's Deepwater Horizon bill tops \$65bn



The Federal Government Says Billions of Animals Died From the BP Disaster

Ex-cable glands

HSK-K-Ex-Active

- Material Polyamide
- Comply with the ATEX guidelines



HSK-M-Ex

- Material: nickel plated brass
- Comply with the ATEX guidelines



HSK-INOX-Ex

- Material: INOX 1.4305
- Comply with the ATEX guidelines



Ex-cable glands for „Hazardous Areas“

EXIOS Standard



EXIOS MZ



EXIOS Barrier



EXIOS A2F



Various accessories all many different possibilities for a wide variety of applications.

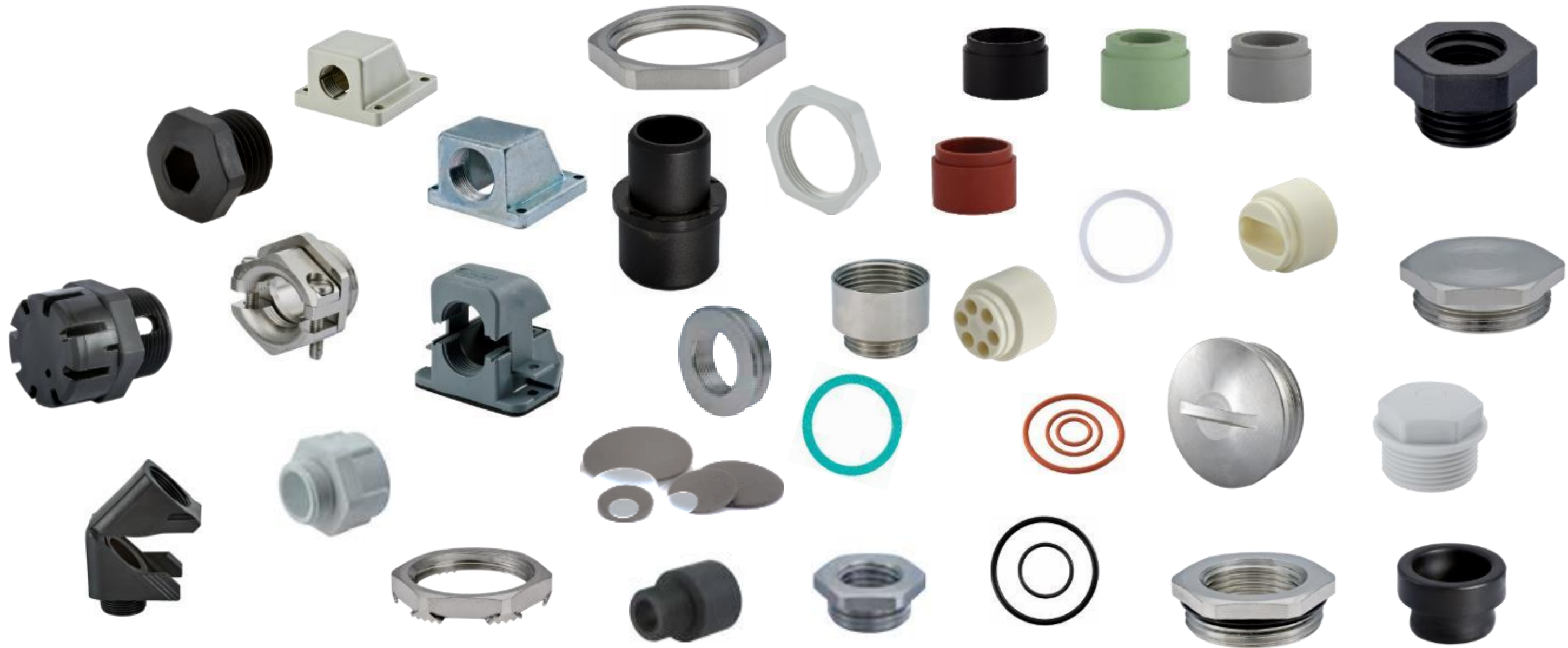

HUMMEL cable glands comply with highest demands of quality and safety. We test our cable glands against a variety of standards, regulations and approvals by different testing institutes, for a usage all over the world.



Strain-relief:

The approval tests are according to the VDE or UL certifications

EN 62444:

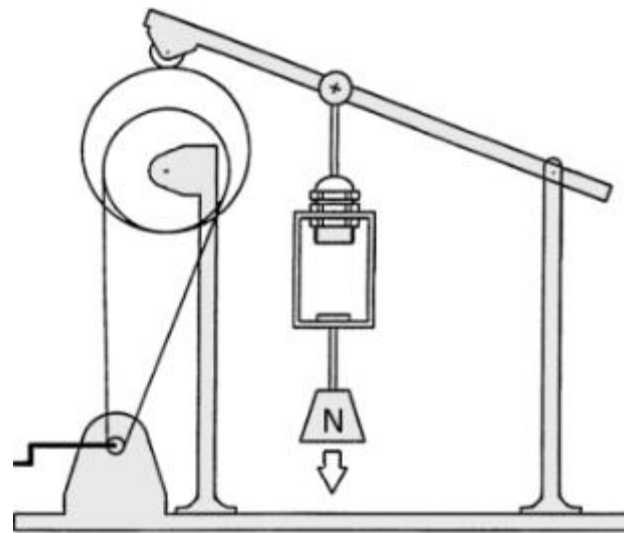

static & dynamic

cable and conducts diameter mm	retention N	strain relief for non-armoured cable and conducts	
		execution A N	execution B N
up to 4	5	–	–
> 4 to 8	10	30	75
> 8 to 11	15	42	120
> 11 to 16	20	55	130
> 16 to 23	25	70	140
> 23 to 31	30	80	250
> 31 to 43	45	90	350
> 43 to 55	55	100	400
> 55	70	115	450

UL 514 B:

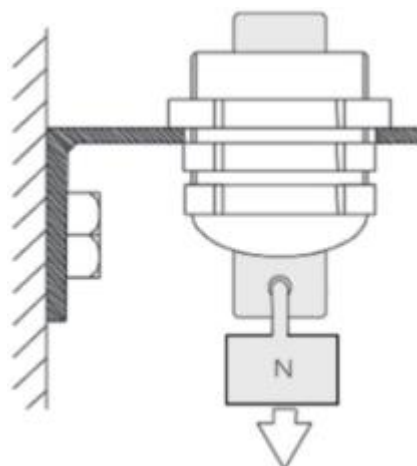

static

Anschlussgewinde			Entlastung
Metrisch	Pg	„NPT	[N]
M12	Pg07	3/8"	30
M16	Pg09, Pg11	1/2"	70
>M16	>Pg11	>1/2"	159

Impact test according to EN 62444: 

Impact tests are testing the resistance of cable glands against impacts cold ambient conditions

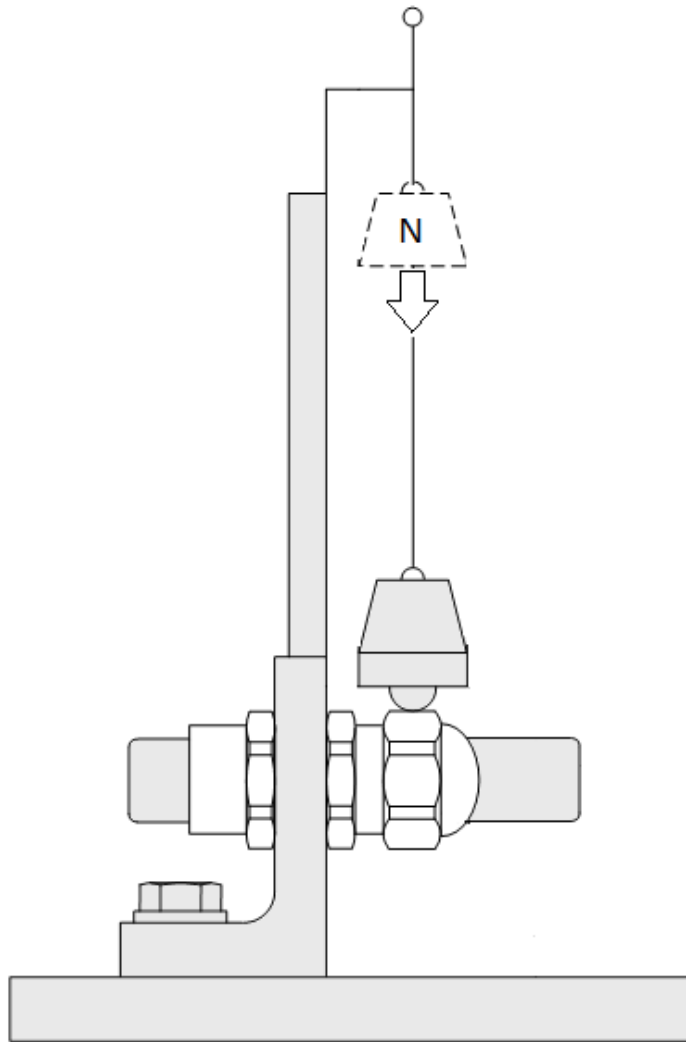

Kategorie	1	2	3	4	5	6	7	8
Energie J	0,2 ±10%	0,5 ±10%	1,0 ±10%	2,0 ±5%	4,0 ±5%	7,0 ±5%	10,0 ±5%	20,0 ±5%
Masse kg	0,2	0,2	0,2	0,2	1,0	1,0	1,0	2,0
Höhe m	0,10	0,25	0,5	1,0	0,4	0,7	1,0	1,0

Quality = Safety

Cable glands are safety-relevant C-parts



- Tyres: 100€
- Rim: 150€
- Valve: 2,50€



- Only very small cost savings possible
- Strongly increasing error risk for the system



Is it worth the risk?

Conclusion / Summary

- HUMMEL offers a **large product portfolio** with many individual options for the customer.
- HUMMEL offers a **variety of approvals and certifications** that allow **worldwide use**.
- HUMMEL uses high **quality raw materials** which are suitable for various application areas.
- HUMMEL stands for **high quality products** and **good service**.



Thank you for your attention!



Your partner for reliable connections

HUMMEL AG